

Profile Edge Mould

2 Wing



Application:

For producing various profiles on the edge of timber from 16mm to 50mm thick. Excellent for both Solid Timber and MDF.

Special Features:

Ground Steel shank and Heat Treated aluminium body ensures precision running, high strength, rigidity, and light weight. Inserts held by secure heavy duty screws for easy change over and minimal spare parts. Tools are 2 wings for smooth running and high chip clearance.

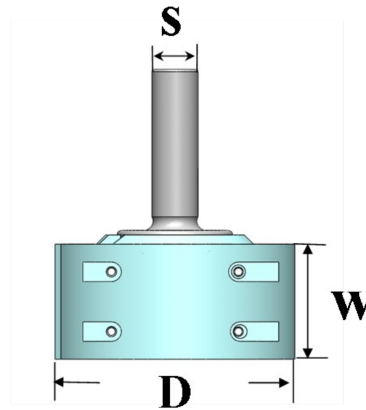

Sizes Available

CODE	D	S	W	No. Wings	Inserts	Screws
DEM 110 3030-25	110	25	30	2	30 x 30 x 2	M4 x 9 HD
DEM 110 3530-25	110	25	35	2	35 x 30 x 2	M4 x 9 HD
DEM 110 5030-25	110	25	50	2	50 x 30 x 2	M4 x 9 HD
DEM 110 5035-25	110	25	50	2	50 x 35 x 2	M4 x 9 HD

Spare Parts

- Insert 30 x 30 x 2 PROFILED
- 35 x 30 x 2 PROFILED
- 50 x 30 x 2 PROFILED
- 50 x 35 x 2 PROFILED
- Screw M4 x 9 HD
- Key T15—TORX

ALL TOOLS ARE CUSTOM PROFILED TO REQUIREMENTS.

Solid Door Profile Router

3+3 Wing

Application:

For use on C.N.C routers or similar machines where a solid timber door profile is required to be machined. Suitable on all solid woods, to produce both cabinet and entry door profiles. All profiles to customer's requirements.

Special Features:

Ground Steel shank and Heat Treated aluminium body ensures precision running high strength, rigidity, and light weight. Inserts held by secure heavy duty screws for easy change over and minimal spare parts. Tools are 3 wings for smooth running and high chip clearance.

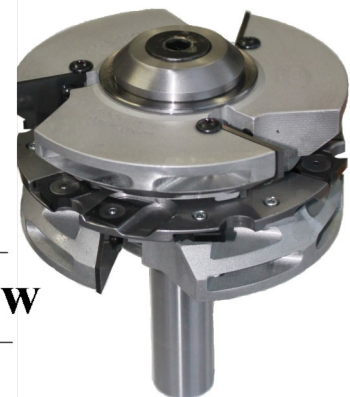
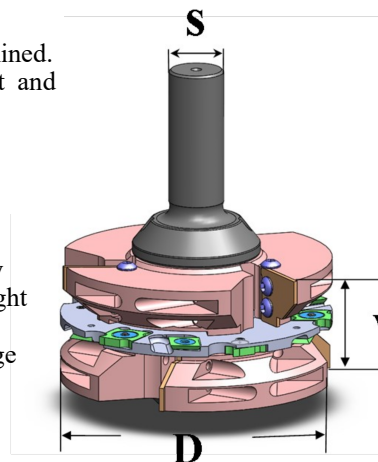

Sizes Available.

CODE	D	S	W	No Wings	Inserts
DFDP 125-2530-25	125	25	80	3+3	25 x 35 x 2 FT
DFDCP 125-2530-25	125	25	80	3+3	25 x 35 x 2 FT
DCDP 125-2530-25	125	25	80	3+3	25 x 35 x 2 FT
DCDCP 125-2530-25	125	25	80	3+3	25 x 35 x 2 FT

Spare Parts

Profile Cutter:

- Insert 25 x 35 x 2 FT PROFILED
- Screw M4 x 8HD
- Key T15 Flag

Groover Cutter:

- Insert 18 x 18 x 3.6
- 14 x 14 x 2 scribe insert
- Washer: WSHR 18
- WSHR 14
- Screw M3 x 6 CSNK-TX

ALL TOOLS ARE CUSTOM PROFILED TO REQUIREMENTS.