

# Adjustable Chamfer Cutter

## 2 Wing



### Application:

For the production of various angled timber, MDF and chipboard moldings up to 50 mm profile width.  
 Angle adjustable from Minus 30 degrees from horizontal to plus 30 degrees horizontal.  
 Total 120 degrees movement.  
 50 mm wide or 60 mm wide cut.  
 Precision turnover knife for high quality finish with long life and quick changeover.  
**Recommended for mechanical feed.**

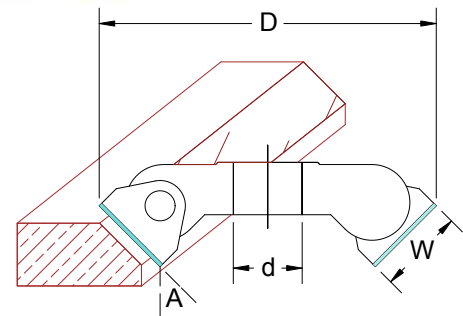

### Sizes Available:

Code	D	W	A	d
SAAC 15050- 11/4	150	50	+ - 60 deg	11/4"
SAAC 15050-40	150	50	+ - 60 deg	40mm
SAAC 15060-11/4	150	60	+ - 60 deg	11/4"
SAAC 15060-40	150	60	+ - 60 deg	40mm

### Spare Parts:

- Inserts. 50 x 12 x 1.5  
60 x 12 x 1.5
- Wedge W5012-TS-T3  
W6012-TS-T3
- Screw M6 X 16 TH
- Key 5AF-TEE

# U' Profile Cutters

## 3 Wing

### Application:

A low cost cutter for low to medium volume production of 'U' and 'L' shape profiles on panels, timber products and other materials.  
 Used on Spindle Moulders, D.E.T and 4-6 head machines.  
 The cutter comes as a fully machined body ready for profiling to your particular profile.  
 The cutter is fitted with 3 blank inserts.  
 Additional inserts can be supplied.  
**Recommended for mechanical feed.**



### Sizes Available

Code	D	W	w	d	Insert
SUP130 2030- 11/4" or 40	130	20	20	11/4" or 40mm	20 x 30 x 2 FT
SUP130 2535- 11/4" or 40	130	25	25	11/4" or 40mm	25 x 35 x 2 FT
SUP130 3535- 11/4" or 40	130	35	35	11/4" or 40mm	35 x 35 x 2 FT
SUP130 4035- 11/4" or 40	130	40	40	11/4" or 40mm	40 x 35 x 2 FT
SUP130 5035- 11/4" or 40	130	50	50	11/4" or 40mm	50 x 35 x 2 FT

### Technical Details:

All Aluminum construction.  
 Balanced design for smooth running.  
 Bores to H7 tolerance.

### Spare Parts :

- Screw. M4 x 9HD
- End Stop M4x9HD
- Key. T15—SD

LAST DIGITS ON CODE NUMBER DENOTES BORE SIZE CHOOSE EITHER 11/4 OR 40.